

## Errata

(1)

This remark corrects an error in section 1.6.1 (second stage of the block decomposition in Jordan normal form). The definition of the invariant subspace  $V'$  in which to repeat the decomposition process after extracting  $[[\mathbf{v}]]$  for some  $\mathbf{v}$  of maximal height, was flawed. More specifically, it was wrongly claimed on page 42 of the notes that, if  $U'_1$  is a linear complement of  $\text{span}(\psi^{h(\mathbf{v})-1}(\mathbf{v}))$  in  $U_1$ , then the vectors  $\mathbf{w}$  for which  $\psi^{h(\mathbf{v})-1}(\mathbf{w}) \in U'_1$  span a  $\varphi$ -invariant linear complement  $V'$  of  $[[\mathbf{v}]]$ .

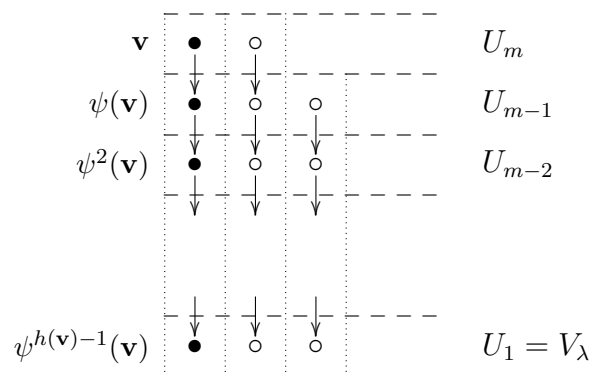

While the  $V'$  thus obtained is  $\varphi$ -invariant and  $V = [[\mathbf{v}]] + V'$ , this latter sum is generally *not* direct. In fact, if  $\mathbf{u} = \psi^{h(\mathbf{v})-1}(\mathbf{v})$  and  $\mathbf{v}' \in V'$  is of height greater than 1, then  $\mathbf{v} + \mathbf{u} \in V'$  too. One clearly has to choose more carefully among the vectors  $\mathbf{w}$  such that  $\psi^{h(\mathbf{v})-1}(\mathbf{w}) \in U'_1$ .

Assume  $\mathbf{v} \in V$  is of maximal height, and that  $V \neq [[\mathbf{v}]]$ . We write  $[[\mathbf{v}]]_i$  for the subspace  $[[\mathbf{v}]] \cap U_i$ , with basis  $(\psi^{h(\mathbf{v})-i}(\mathbf{v}), \dots, \psi^{h(\mathbf{v})-1}(\mathbf{v}))$ .

Starting (as before) with any  $U'_1$  such that

$$U_1 = [[\mathbf{v}]]_1 \oplus U'_1,$$

we now inductively choose subspaces  $U'_i \subseteq U_i$  such that

- (i)  $U'_i \subseteq U'_{i+1}$ .
- (ii)  $U_i = [[\mathbf{v}]]_i \oplus U'_i$ .
- (iii)  $\psi(U'_{i+1}) \subseteq U'_i$ .

Then  $V' := U'_m$  will be such that

$$V = \llbracket \mathbf{v} \rrbracket \oplus V'$$

is a decomposition of  $V$  into a direct sum of subspaces that are invariant under  $\varphi$ . Here  $V = \llbracket \mathbf{v} \rrbracket \oplus V'$  is clear from (ii), as  $V = U_m$  and  $\llbracket \mathbf{v} \rrbracket = \llbracket \mathbf{v} \rrbracket_m$ . Invariance of  $V'$  under  $\varphi$  follows from (iii) and (i), as  $\varphi = \psi + \lambda \text{id}$ .

It remains to show that, for  $i = 1, \dots, m-1$ ,  $U'_{i+1}$  can be chosen as required in relation to the previously chosen  $U'_i$ . Let  $U'_i$  be as required,  $B'_i$  a basis of  $U'_i$ . Then the basis  $(\psi^{h(\mathbf{v})-i}(\mathbf{v}), \dots, \psi^{h(\mathbf{v})-1}(\mathbf{v}))$  of  $\llbracket \mathbf{v} \rrbracket_i$  extends  $B'_i$  to a basis  $B_i$  of  $U_i = \llbracket \mathbf{v} \rrbracket_i \oplus U'_i$  by (ii). As  $\psi^{h(\mathbf{v})-(i+1)}(\mathbf{v})$  has height  $i+1$ , it is linearly independent from  $B_i$ . We now want to extend the linearly independent  $B_i \cup \{\psi^{h(\mathbf{v})-(i+1)}(\mathbf{v})\}$  to a basis  $B_{i+1}$  of  $U_{i+1}$  using new basis vectors  $\mathbf{b}$  for which  $\psi(\mathbf{b}) \in U'_i$ . Then  $B'_{i+1} := B_{i+1} \setminus \{\psi^{h(\mathbf{v})-(i+1)}(\mathbf{v}), \psi^{h(\mathbf{v})-i}(\mathbf{v}), \dots, \psi^{h(\mathbf{v})-1}(\mathbf{v})\}$  can serve as a basis for the desired  $U'_{i+1}$ . Such an extension is possible due to the following claim.

**Claim 1.6.5**  $U_{i+1} \subseteq \llbracket \mathbf{v} \rrbracket_{i+1} + \{\mathbf{w} \in U_{i+1} : \psi(\mathbf{w}) \in U'_i\}$ .

**Proof.** Consider  $\mathbf{w} \in U_{i+1} \setminus U_i$ . Since  $h(\mathbf{w}) = i+1$ ,  $h(\psi(\mathbf{w})) = i$  and, by (ii) for  $U'_i$ ,  $\psi(\mathbf{w}) = \mathbf{v}' + \mathbf{u}'$  for suitable  $\mathbf{v}' \in \llbracket \mathbf{v} \rrbracket_i$  and  $\mathbf{u}' \in U'_i$ . Let  $\mathbf{v}' = \sum_{1 \leq j \leq i} \lambda_j \psi^{h(\mathbf{v})-j}(\mathbf{v})$ . Putting  $\mathbf{v}'' := \sum_{1 \leq j \leq i} \lambda_j \psi^{h(\mathbf{v})-j-1}(\mathbf{v})$ , we have  $\mathbf{v}'' \in \llbracket \mathbf{v} \rrbracket_{i+1}$  and  $\psi(\mathbf{v}'') = \mathbf{v}'$ . Now  $\mathbf{w} = \mathbf{v}'' + (\mathbf{w} - \mathbf{v}'')$  and  $\psi(\mathbf{w} - \mathbf{v}'') = \psi(\mathbf{w}) - \psi(\mathbf{v}'') = \psi(\mathbf{w}) - \mathbf{v}' = \mathbf{u}' \in U'_i$  shows that  $\mathbf{w} \in \llbracket \mathbf{v} \rrbracket_{i+1} + \{\mathbf{w} \in U_{i+1} : \psi(\mathbf{w}) \in U'_i\}$ . □

(2)

This corrects a mistake in the proof of part (i) of Lemma 3.2.3 on page 84 of the notes. In the case that  $\varphi$  is irregular, consider  $\mathbf{v} \in \text{image}(\varphi)^\perp \setminus \{\mathbf{0}\}$  to show that  $\langle \cdot, \cdot \rangle_\varphi$  is degenerate (and not  $\mathbf{v} \in \ker(\varphi) \setminus \{\mathbf{0}\}$  as stated).

The online version of the notes has been corrected accordingly.